



100W High Bay

Pendant style High Bay with Premium Performance

Optional microwave motion sensor, aluminum reflector, PC reflector, anti-glare kit, yoke, and emergency battery back-up kit available

Polyester
Powder Coat
Finish

High-impact
tempered glass with
high light transmittance

IP65

Rugged Cast Aluminum

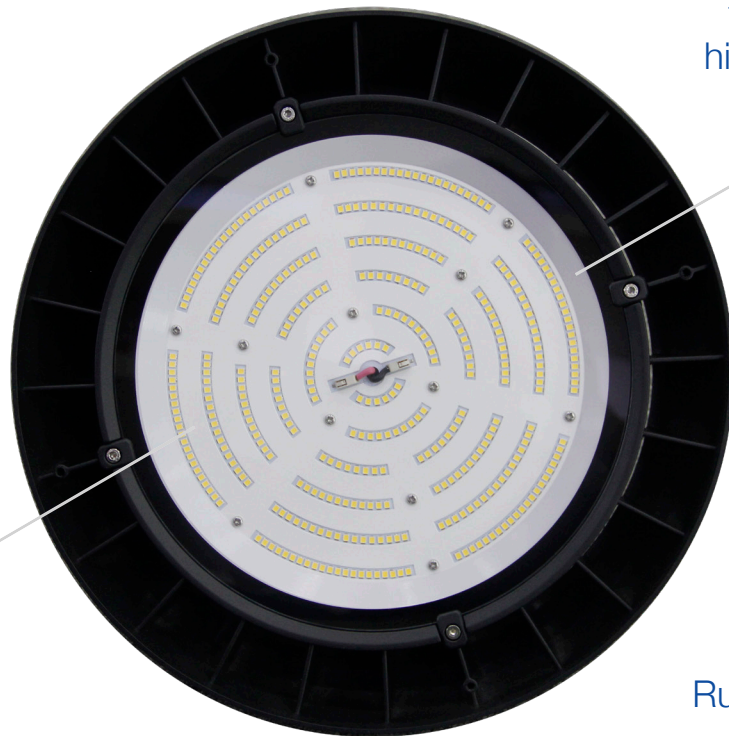

0-10V
Dimmable



Shown with optional
Dimmable Motion Sensor



Shown with optional
Emergency Battery
Back Up Kit



Shown with optional
Frosted Polycarbonate
Lens



Shown with optional
Clear Polycarbonate
Lens



TECHNICAL DATA



LIGHT SPECIFICATIONS

Lumens	13,241
Efficacy	131.49 lm/W
CCT	4000K
Beam angle	110°
CRI	84.1
Dimmable	0-10V
Rated hours	50,000
Warranty	5-year

APPROVALS AND LISTINGS

cUL	E482965
DLC PREMIUM	PLCHVZBV67J1

DIMENSIONS

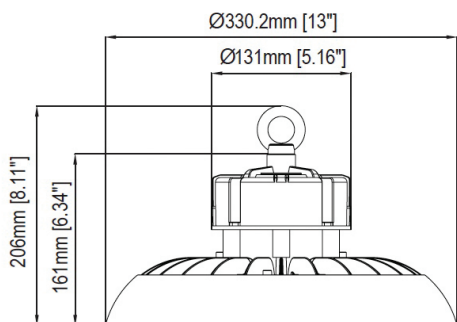

ELECTRICAL

Wattage	100W
Voltage	120-277V
Power factor	0.97
THD	9.25%
Operating temp	-40 to 40°C

CONSTRUCTION

Housing	Cast Aluminum
Finish	Powder Coat
Colour	Black
IP rating	IP65
Weight	9.2 lbs
Carton qty	1

INSTALLATION INSTRUCTIONS

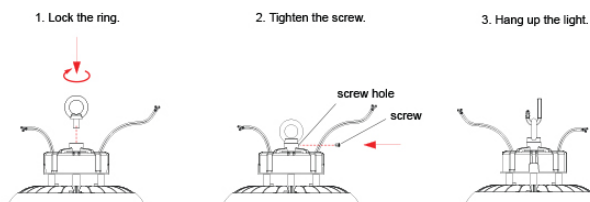

ILLUMINANCE AT A DISTANCE

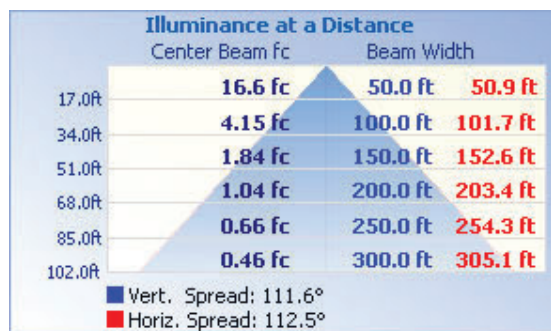

ACCESSORIES

Microwave Motion Sensor Kit	HBP-MMS-KIT
Aluminum Reflector	HBP-AL-REF-A
Anti-glare Kit	HBP-AGK-A
Yoke Mount	HBP-YK-A
Emergency Battery Backup Kit	HBP-EBU
Polycarbonate Frosted Lens	HBP-FR-LENS-A
Polycarbonate Lens	HBP-PC-LENS-A
PC Reflector (100W/150W)	HBP-PC-REF-A