



100W High Bay

Pendant style High Bay with Premium Performance
 Optional microwave motion sensor, aluminum reflector, PC reflector, anti-glare kit, yoke, and emergency battery back-up kit available

Polyester
 Powder Coat
 Finish

High-impact
 tempered glass with
 high light transmittance

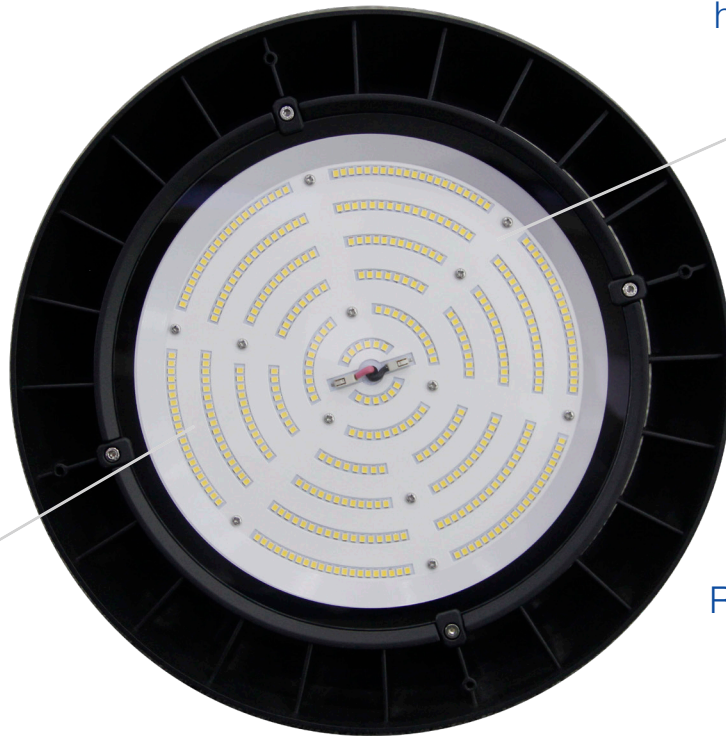

IP65

Rugged Cast Aluminum

0-10V
 Dimmable



Shown with optional
 Dimmable Motion Sensor



Shown with optional
 Emergency Battery
 Back Up Kit



Shown with optional
 Frosted Polycarbonate
 Lens



Shown with optional
 Clear Polycarbonate
 Lens



TECHNICAL DATA



LIGHT SPECIFICATIONS

Lumens	13,392
Efficacy	132.59 lm/W
CCT	5000K
Beam angle	110°
CRI	84.1
Dimmable	0-10V
Rated hours	50,000
Warranty	5-year

APPROVALS AND LISTINGS

cUL	E482965
DLC PREMIUM	PLU4M2MFSYYP

DIMENSIONS

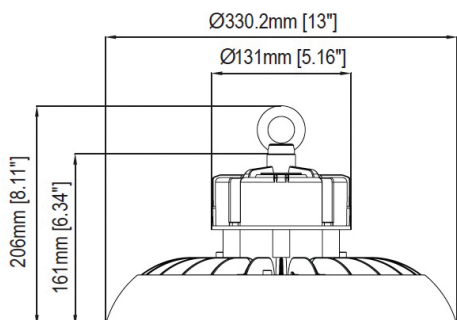

ELECTRICAL

Wattage	100W
Voltage	120-277V
Power factor	0.97
THD	9.25%
Operating temp	-40 to 40°C

CONSTRUCTION

Housing	Cast Aluminum
Finish	Powder Coat
Colour	Black
IP rating	IP65
Weight	9.2 lbs
Carton qty	1

INSTALLATION INSTRUCTIONS

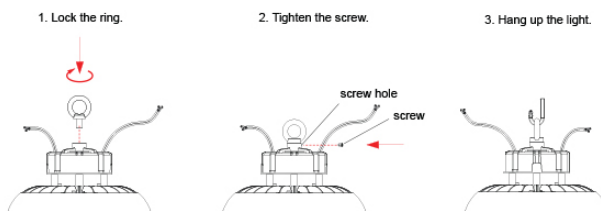

ILLUMINANCE AT A DISTANCE

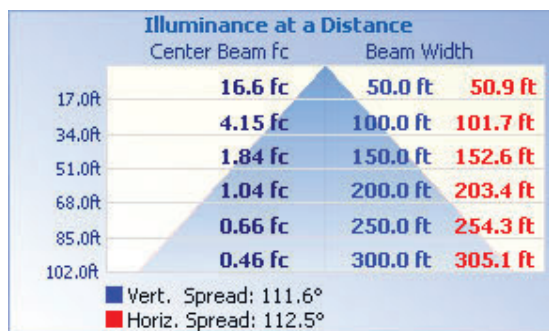

ACCESSORIES

Microwave Motion Sensor Kit	HBP-MMS-KIT
Aluminum Reflector	HBP-AL-REF-A
Anti-glare Kit	HBP-AGK-A
Yoke Mount	HBP-YK-A
Emergency Battery Backup Kit	HBP-EBU
Polycarbonate Frosted Lens	HBP-FR-LENS-A
Polycarbonate Lens	HBP-PC-LENS-A
PC Reflector (100W/150W)	HBP-PC-REF-A