



# 240W High Bay, HV

Pendant style High Bay with Premium Performance

Optional microwave motion sensor, aluminum reflector, PC reflector, anti-glare kit, and yoke available

Polyester Powder Coat Finish

High-impact tempered glass with high light transmittance

IP65

Rugged Cast Aluminum

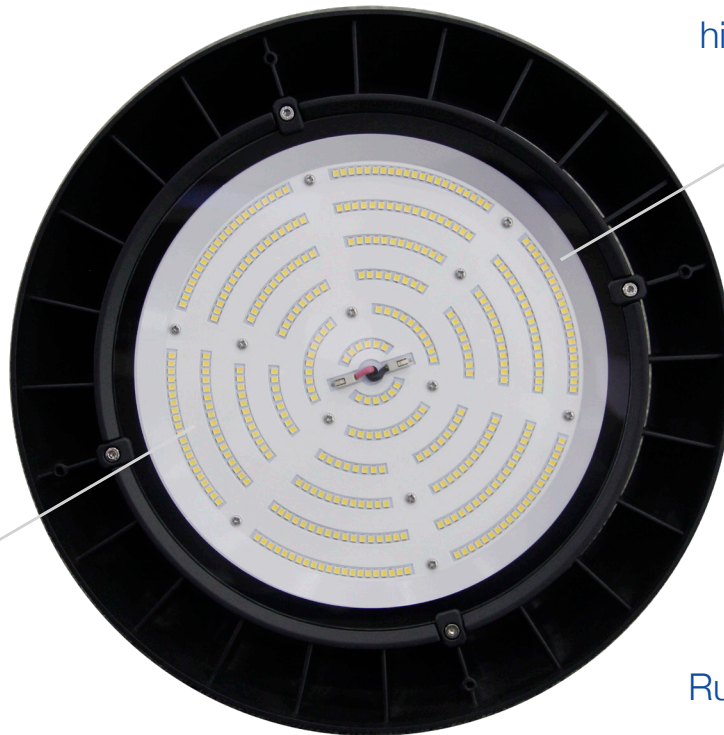

0-10V Dimmable



Shown with optional Dimmable Motion Sensor



Shown with optional Frosted Polycarbonate Lens



Shown with optional Clear Polycarbonate Lens

## TECHNICAL DATA



### LIGHT SPECIFICATIONS

Lumens	31,478
Efficacy	132.43 lm/W
CCT	4000K
Beam angle	110°
CRI	80
Dimmable	0-10V
Rated hours	50,000
Warranty	5-year

### APPROVALS AND LISTINGS

cUL	E482965
DLC PREMIUM	PLTCXS3OL2W6

### DIMENSIONS

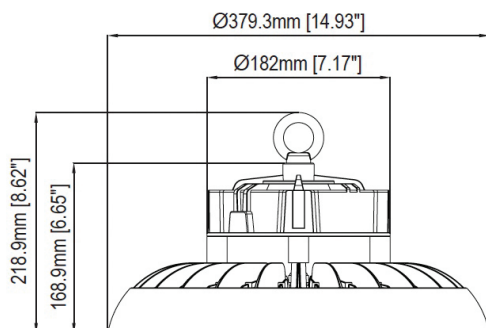

### ELECTRICAL

Wattage	240W
Voltage	277-480V
Power factor	0.88
THD	15%
Operating temp	-40 to 40°C

### CONSTRUCTION

Housing	Cast Aluminum
Finish	Powder Coat
Colour	Black
IP rating	IP65
Weight	13 lbs
Carton qty	1

### INSTALLATION INSTRUCTIONS

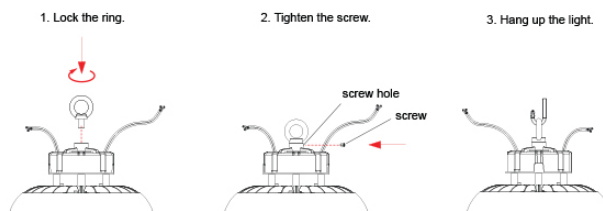

### ILLUMINANCE AT A DISTANCE

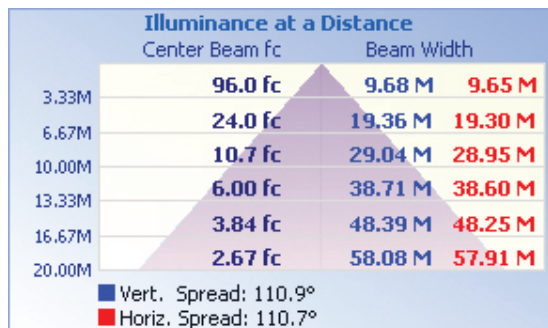

### ACCESSORIES

Microwave Motion Sensor Kit	HBP-MMS-KIT
Aluminum Reflector	HBP-AL-REF-B
Anti-glare Kit	HBP-AGK-B
Yoke Mount	HBP-YK-B
Emergency Battery Backup Kit	HBP-EBU
Polycarbonate Frosted Lens	HBP-FR-LENS-B
Polycarbonate Lens	HBP-PC-LENS-B
PC Reflector (200W/240W)	HBP-PC-REF-B