

Mini Wall Pack

15W | 3000K | 100-277V

Powerful performance in an attractive package
Ideal for security lighting, commercial entrances and more



TECHNICAL DATA



LIGHT SPECIFICATIONS

Lumens	1,931 lm
Efficacy	127.58 lm/W
CCT	3000K
CRI	83
L70 Life	50,000 hrs
Dimmable	No
Warranty	5-year

APPROVALS AND LISTINGS

cUL	E482965
-----	---------

ELECTRICAL

Wattage	15W
Voltage	100-277V
Power Factor	0.87
THD	17.77%
Operating Temp	-40 to 45°C

CONSTRUCTION

Housing	Aluminum
Colour	Bronze
IP Rating	IP65
Weight	1.98 lbs
Carton Qty	10

ILLUMINANCE AT A DISTANCE

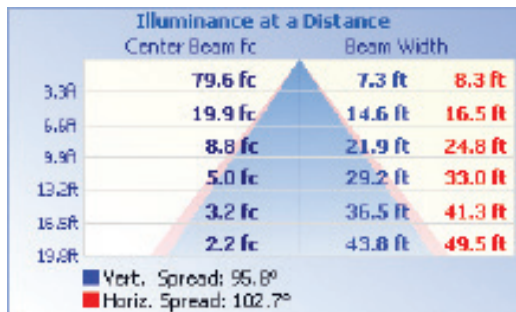

ISOCANDELA PLOT

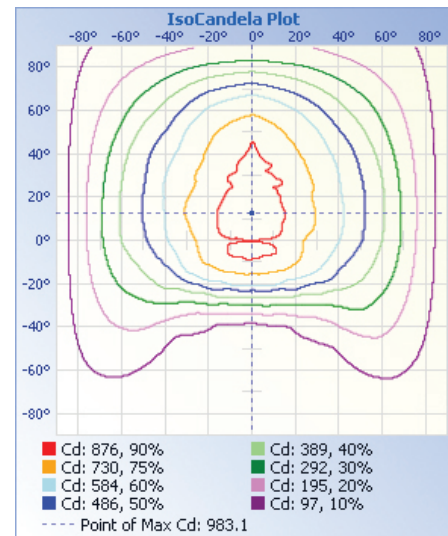

DIMENSIONS

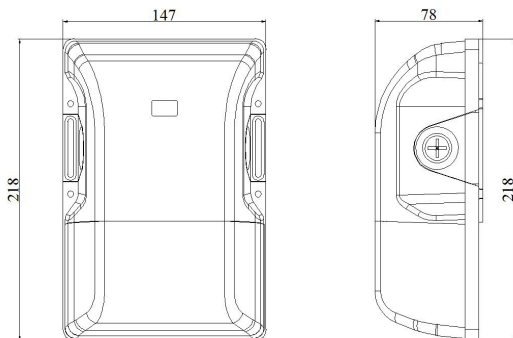

Western Canada Warehouse: 121-1647 Broadway Street, Port Coquitlam, BC V3C 6P8 | ordersbc@csc-led.com